

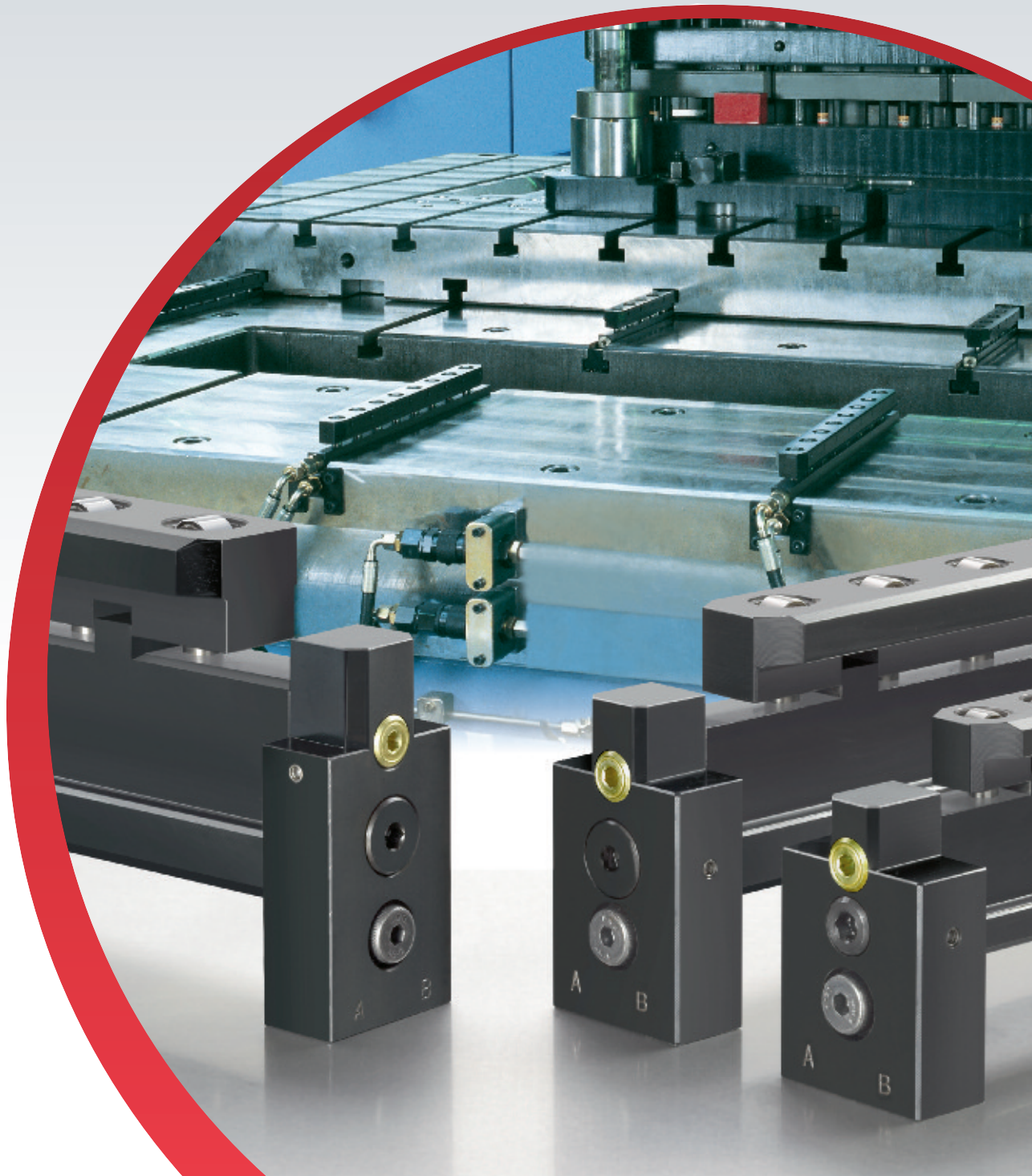

**GÜTHLE**  
*IDEA AND SYSTEMS*

# QUICK DIE CHANGE **CLAMP TECHNOLOGY**

**DILOS SLIPGRIP**



# DILOS SLIPGRIP

## GUIDING, CARRYING & CLAMPING DIES



### Compact automation technology

The technology of the DILOS SlipGrip SGR...H... combines all the functions necessary for die changing and die clamping.

The die base plate is guided precisely during the die changing sequence and carried by the hydraulically lifted rollers.

The hydraulic clamping pressure is applied along the complete length of the double-T-ledge clamp of the DILOS SlipGrip.

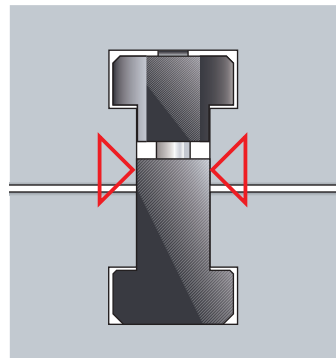

Guiding

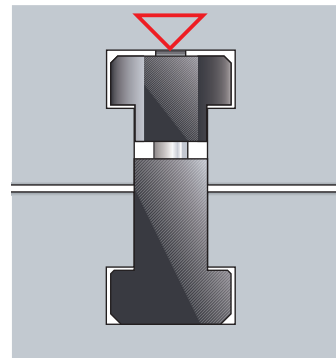

Carrying

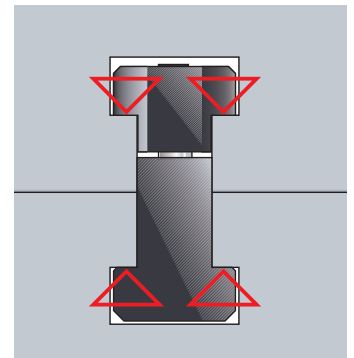

Clamping

### For use in T-slots per DIN 650

In order to use the SlipGrip application, T-slots per DIN 650 are needed on the press side. The die base plates and sub plates must also be equipped with suitable T-slots.

### Dual acting hydraulic function

Hydraulic cylinders are used to lift the roller elements and to generate the clamping force.

To prevent overloading, the support rollers are lifted individually by a piston each so that the weight is supported uniformly. A 'floating' connection is used to connect the pistons to the ledge clamp.

### Comfortable clamping in the centre of forces

The integral installation in the press table allows the pulling forces exerted to be absorbed from the shortest distance possible. This results in a high force density with optimum force distribution.

Additional SlipGrip ledge clamps can be used to increase the clamping force.

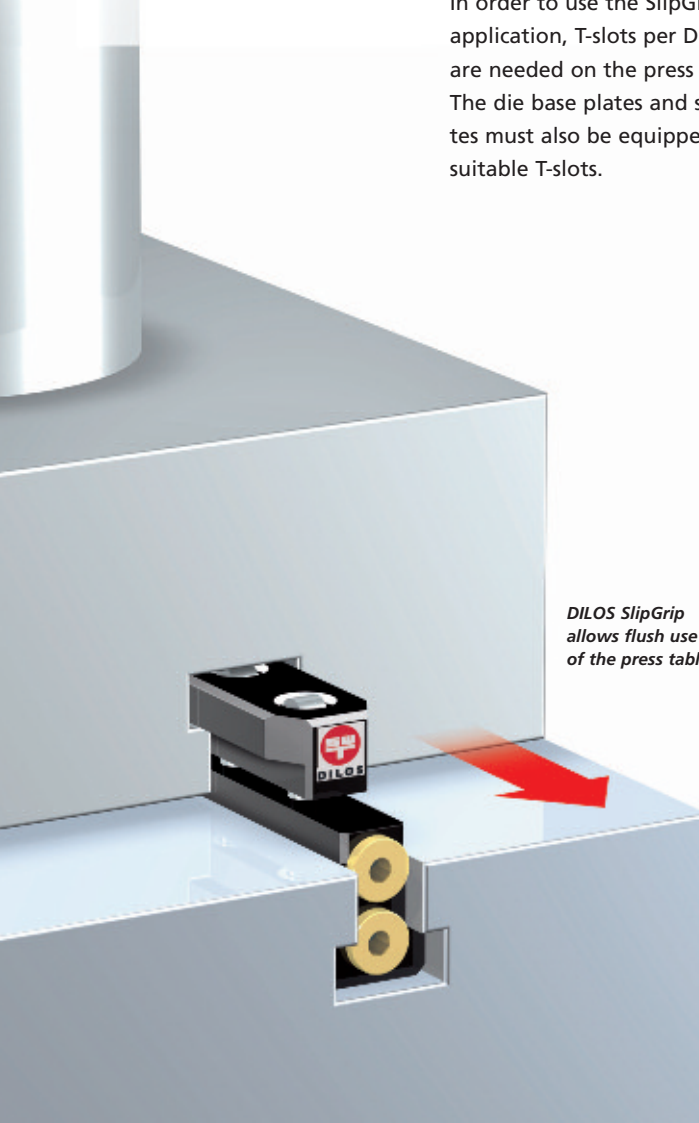

DILOS SlipGrip allows flush use of the press table



DILOS Swing Sink Clamp, the perfect complement for automated clamping of the top part of a die

### Complete automation

In addition to the DILOS SlipGrip versions SGS...F... and SGS...H..., DILOS Swing Sink Clamps are also ideally suitable for clamping the top part of dies without manual intervention.

Mixed use of a SlipGrip in the press table and Swing Sink Clamp in the ram is the perfect solution for presses whose rams cannot be positioned vertically exactly during a die change



**GÜTHLE**

**DILOS**

# ALSO IDEAL FOR INTERCHANGEABLE DIE SUBPLATES

## DILOS subplate technology

If dies with differently dimensioned base plates are used on a press, it is still possible to streamline the die changing process by using DILOS subplates.

The rail-mounted DILOS SHUTTLE and free-travelling DILOS TRUCK are ideally suited to transport DILOS subplates.



*Subplate technology. Press table equipped with DILOS SlipGrip SGR28H, press ram equipped with DILOS Swing Sink Clamp*

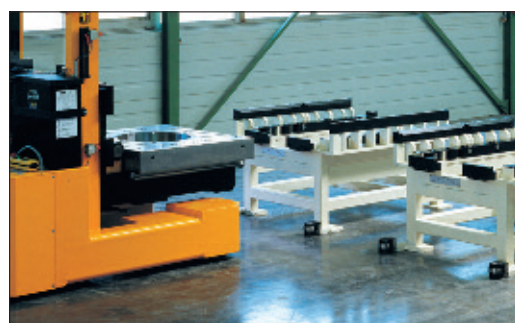

*Die presetting is performed at special subplate assembly stations, allowing preparatory set-up work to be carried out at the same time as production*

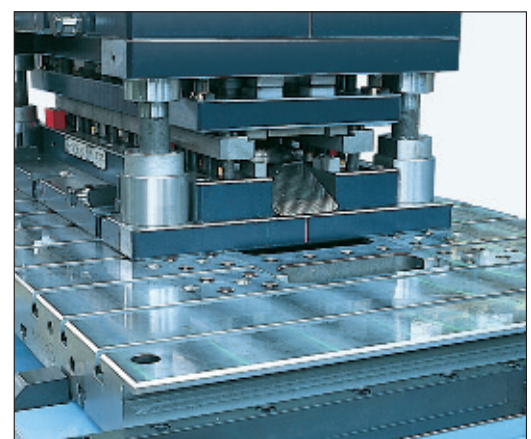

*DILOS die subplates are custom built and come with the necessary T-slots, hole patterns and clearance holes for scrap material*



*DILOS SHUTTLE with die on subplate*

# DILOS SLIPGRIP FOR TABLE-FLUSH DIE BASE PLATES OR SUBPLATES

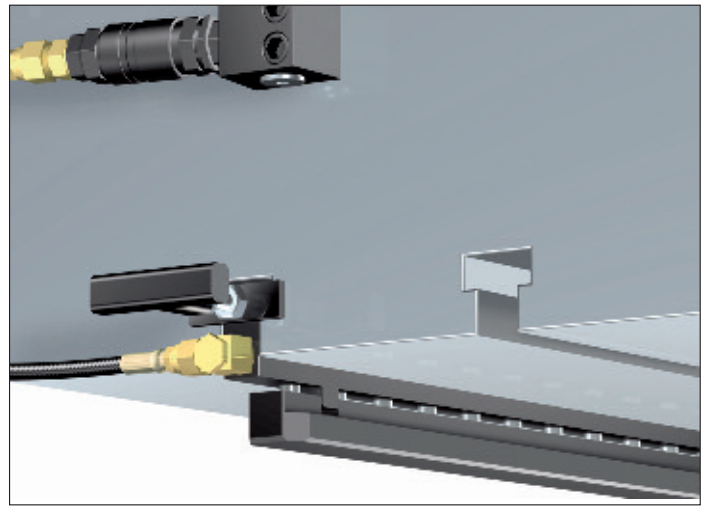
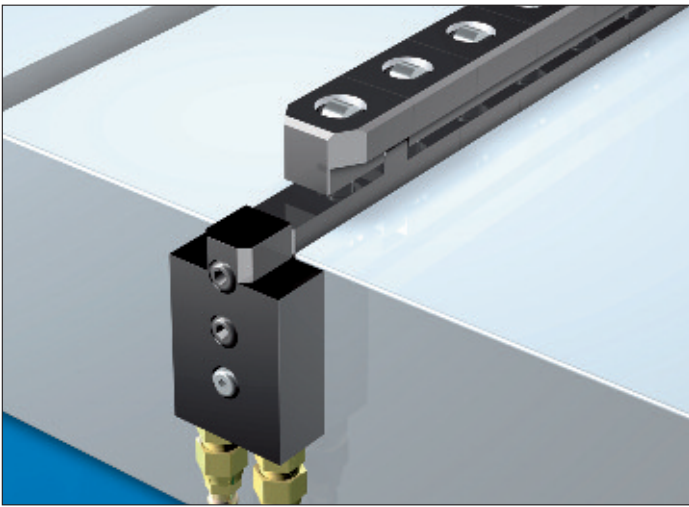

## DILOS SlipGrip SGR...H...

Double-T-ledge clamp with support rollers. Basic version for press tables. Hydraulic connection via fixing block.

With dual acting hydraulic cylinders for clamping and resetting. Actuation via hydraulic valve set type S...

## DILOS SlipGrip SGS...F...

Manually insertable double-T-ledge clamp. Clamping force generated hydraulically, resetting by spring power.

Thanks to the quick-action coupling, the hose connection permits convenient usage as a sliding clamp. Actuation via hydraulic valve set type E...

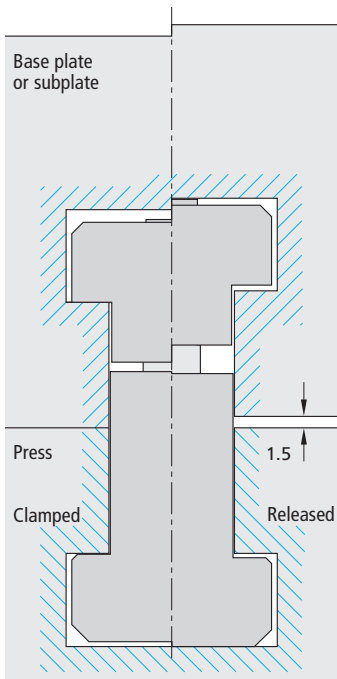

Lift for all sizes 1.5 mm

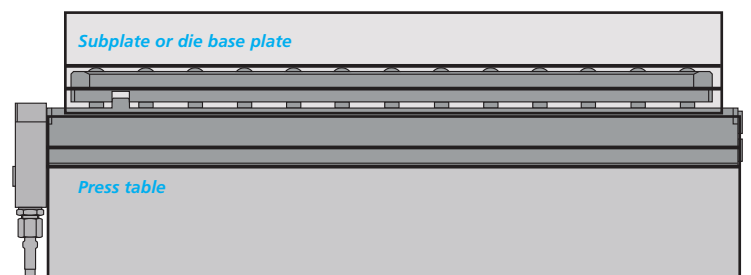
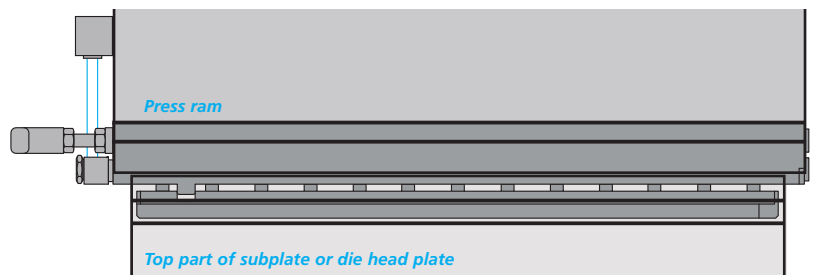



**GÜTHLE**

**DILOS**

## ... SET-BACK DIES CAN ALSO BE CHANGED AUTOMATICALLY

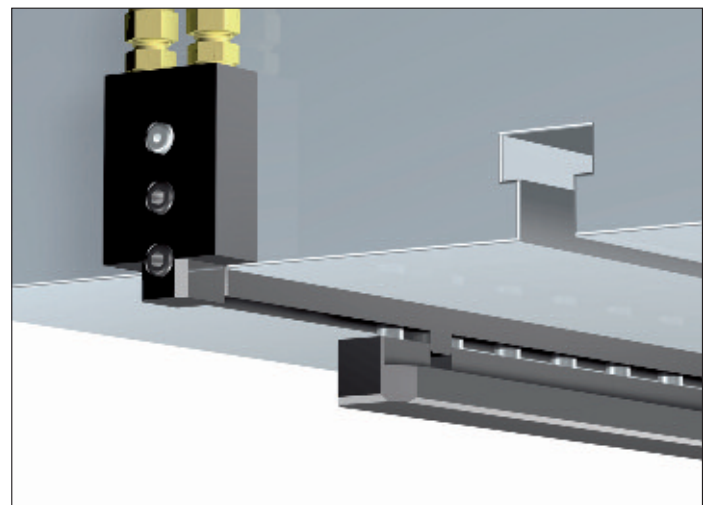
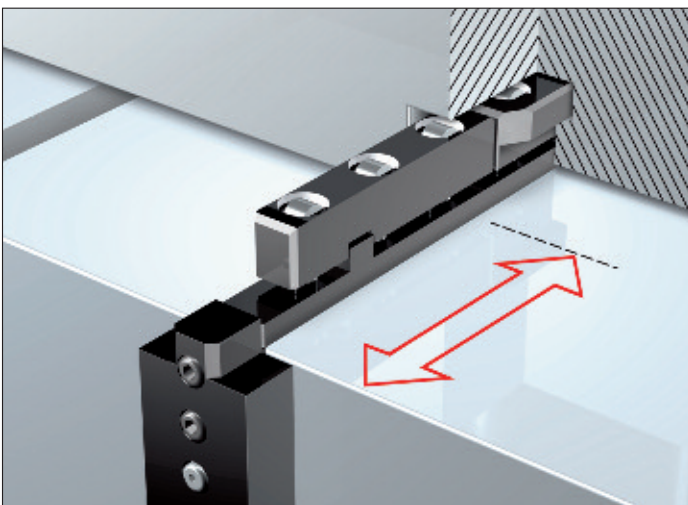

### DILOS SlipGrip SGR...H...

Double-T-ledge clamp with separate version for clamping and a clamping-free overtravel zone. The overtravel element is

equipped with support rollers, but does not have clamping edges. Actuation via hydraulic valve set type S...

### Clamping-free overtravel zone

If the die base plates are shorter than the press table in rolling direction, it is necessary to distinguish between the clamping area and the clamping-free zone. Fundamentally care must be taken to ensure that a SlipGrip hydraulic piston does not clamp "into thin air".

Special versions permit individual adaptation to the clamping-free zone. The overtravel element does not have clamping edges. Its sole purpose is to perform a carrying function.

Important: An empty zone might have to be taken into account when dimensioning the length of the SlipGrip.

### DILOS SlipGrip SGS...H...

Version as double-T-ledge clamp (hydraulic clamping and releasing) with set-back clamping area. Prerequisite for use of this SlipGrip is a **positionable press ram**.

The die change can then be automated fully. Actuation via hydraulic valve set type S...

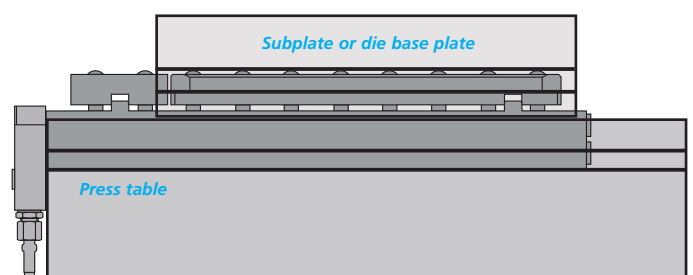
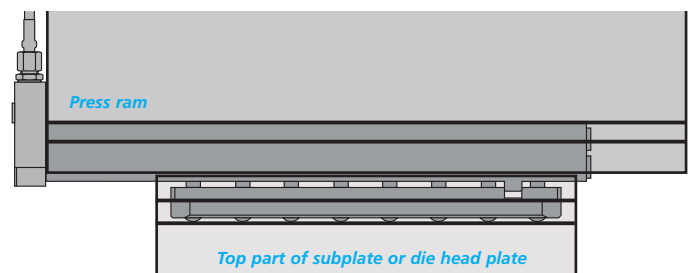
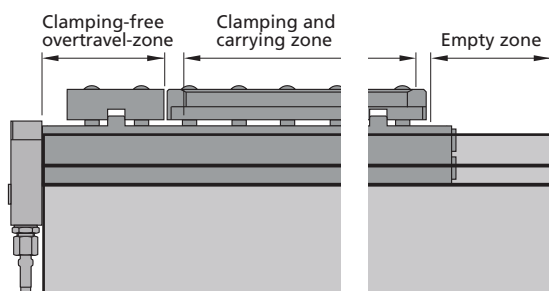

# DILOS SLIPGRIP

## THE TIME-SAVING DOUBLE-T-LEDGE CLAMP

### DILOS SlipGrip for T-slot 18

#### SlipGrip double-T-ledge clamp SGR18H... for T-slot 18

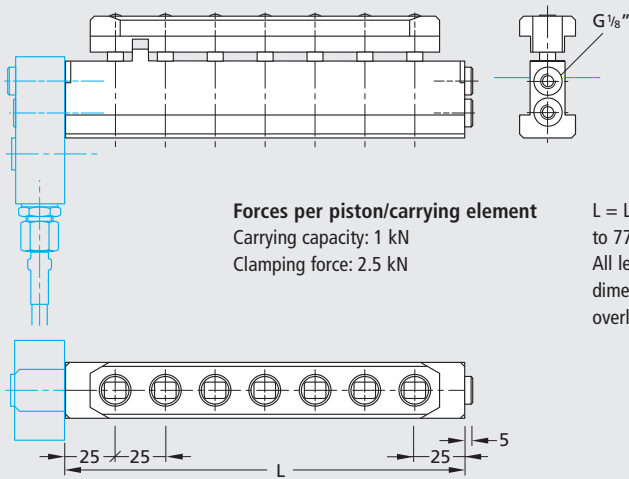

**Forces per piston/carrying element**  
 Carrying capacity: 1 kN  
 Clamping force: 2.5 kN

L = Length: from 100 mm (3 pistons)  
 to 775 mm (30 pistons)  
 All lengths divisible in modular  
 dimension available,  
 overlengths on request

Shown with fixing block

#### SlipGrip fixing block SGF18

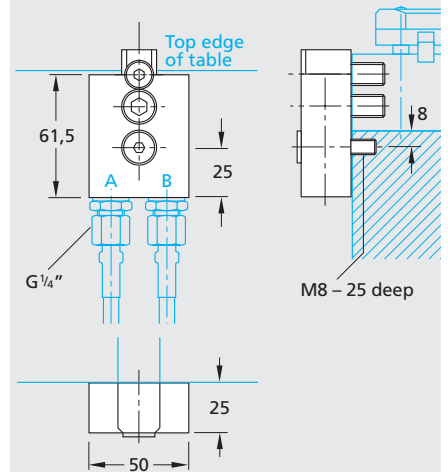

### DILOS SlipGrip for T-slot 22

#### SlipGrip double-T-ledge clamp SGR22H... for T-slot 22

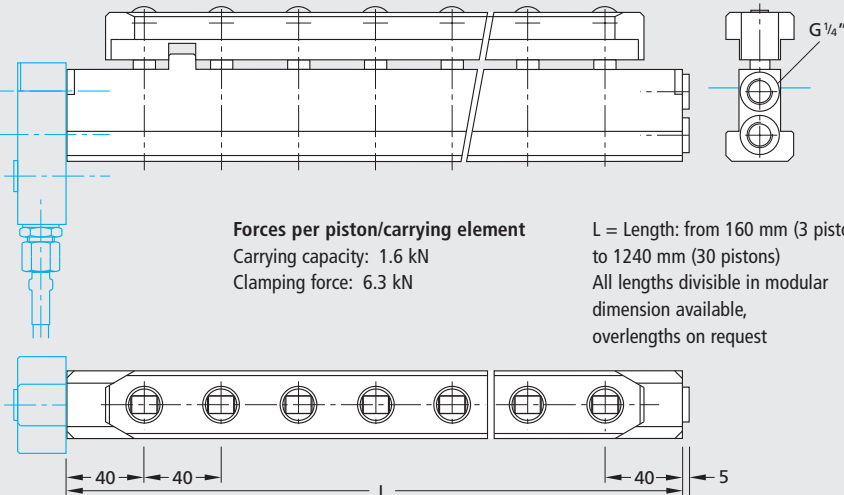

**Forces per piston/carrying element**  
 Carrying capacity: 1.6 kN  
 Clamping force: 6.3 kN

L = Length: from 160 mm (3 pistons)  
 to 1240 mm (30 pistons)  
 All lengths divisible in modular  
 dimension available,  
 overlengths on request

Shown with fixing block

#### SlipGrip fixing block SGF22

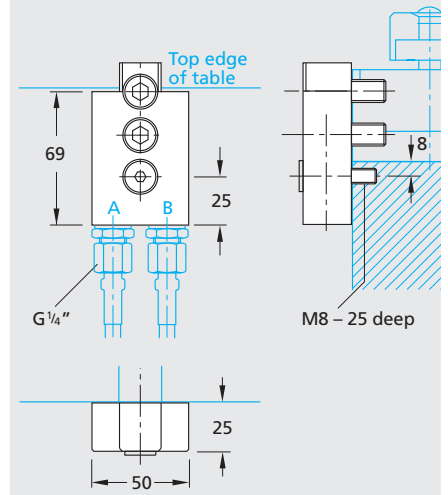



**GÜTHLE**

**DILOS**

# THE FULL PROGRAMME FOR T-SLOTS PER DIN 650

## DILOS SlipGrip for T-slot 28 Application example: for clamping-free overtravel zone

### SlipGrip double-T-ledge clamp SGR28H... for T-slot 28

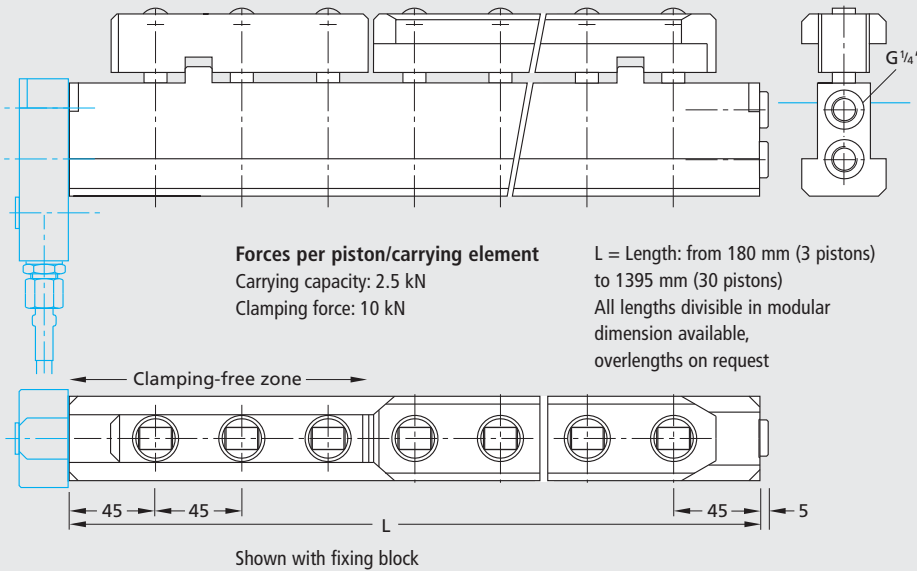

### SlipGrip fixing block SGF28

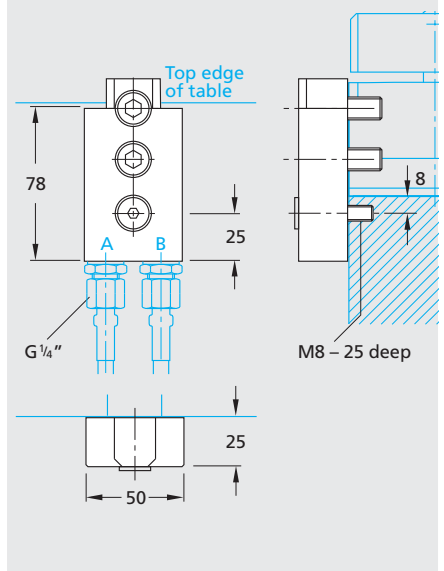

## DILOS SlipGrip for T-slot 36 Application example: for rear connection

### SlipGrip double-T-ledge clamp SGR36H... for T-slot 36

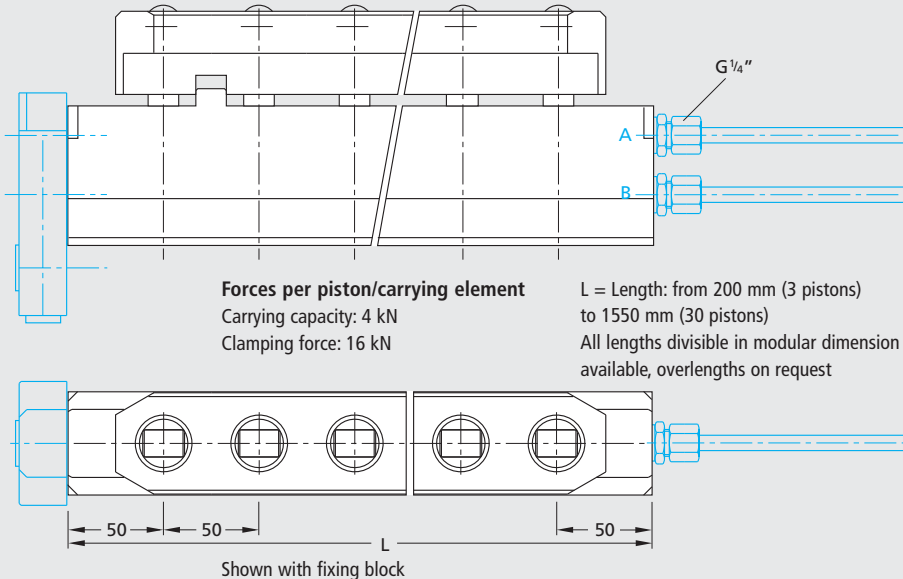

### SlipGrip fixing block SGF36

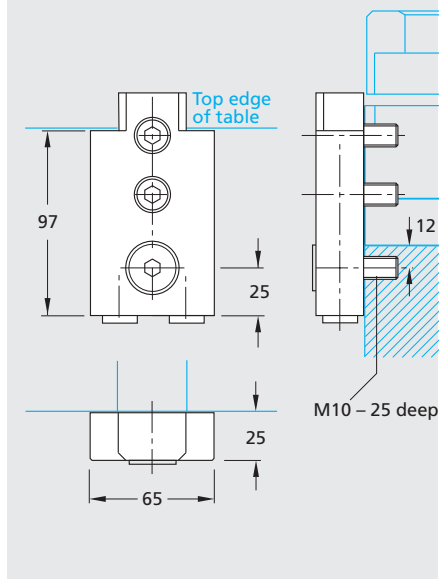

# DILOS SLIPGRIP FOR RAM PLATES

## DILOS SlipGrip – Application for ram

SlipGrip double-T-ledge clamp SGS22F... Example for T-slot 22 with handle and detachable stop, without carrying elements

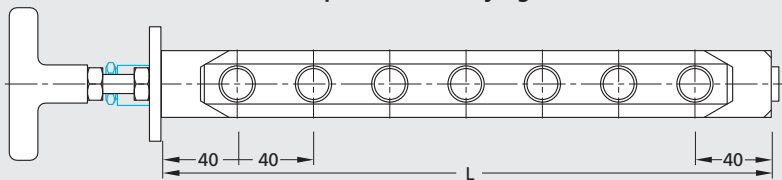

**Forces per piston**  
Clamping force: 6.3 kN

L = Length: from 160 mm (3 pistons)  
to 1240 mm (30 pistons)  
All lengths divisible in modular dimension  
available, overlengths on request

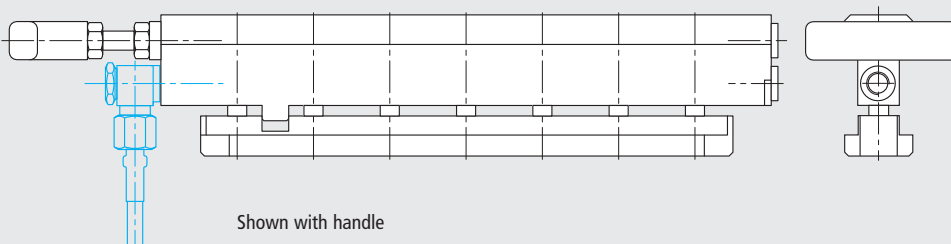

Shown with handle

SlipGrip handle to size 28

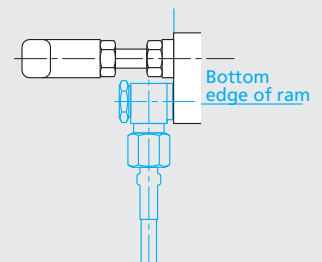
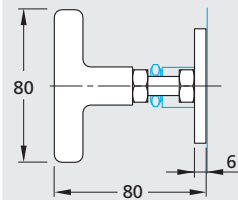

## DILOS SlipGrip – Application for ram

SlipGrip double-T-ledge clamp SGS22F... Example for T-slot 22, with spring return, for exactly positionable ram with clamping-free zone through shortened ledge clamp

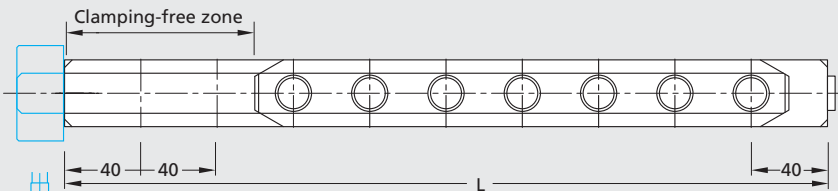

**Forces per piston**  
Clamping force: 6.3 kN

L = Length: from 160 mm (3 pistons)  
to 1240 mm (30 pistons)  
All lengths divisible in modular dimension  
available, overlengths on request

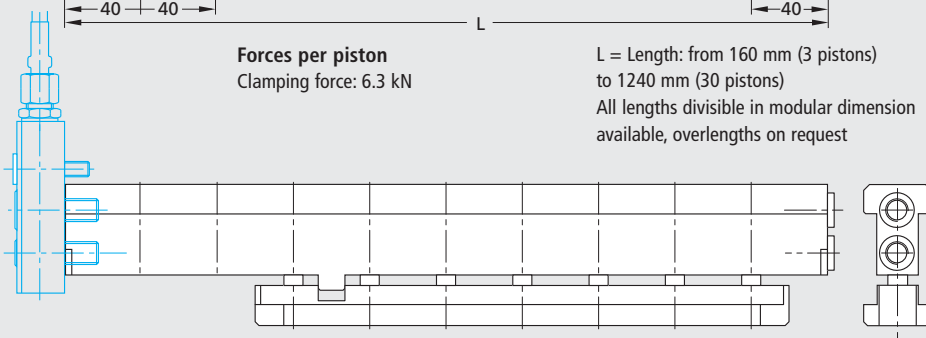

Shown with fixing block

Shown with fixing block

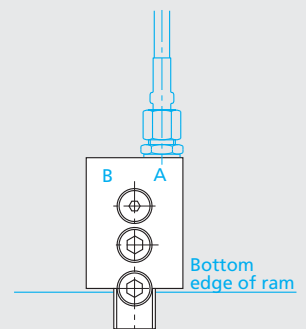





# DILOS SLIPGRIP

## CARRYING CAPACITY AND CLAMPING FORCE RISE WITH LENGTH

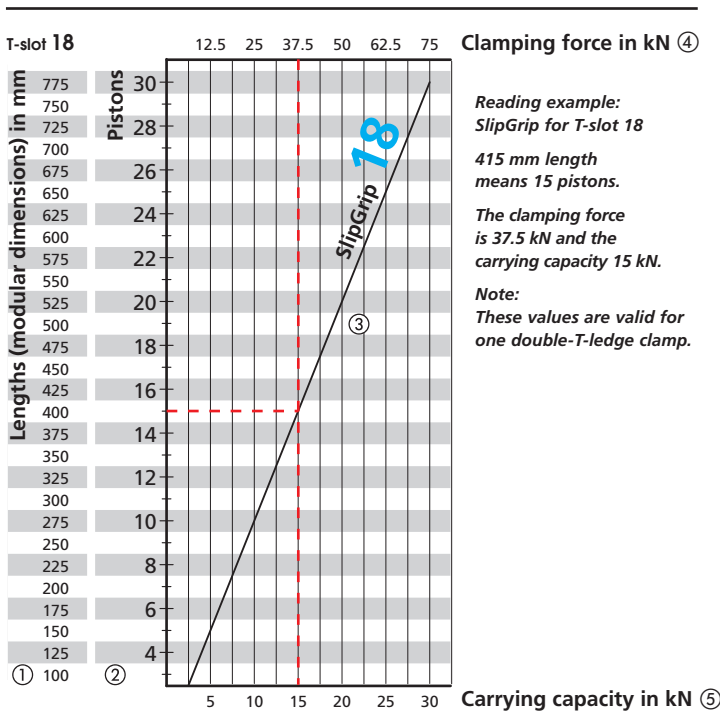

### SlipGrip dimensioning

#### Determining the necessary carrying capacity and clamping force

The carrying capacity and clamping force are based on the die dimensions (in slide direction).

The spacing between the hydraulic pistons defines the modular dimensions ①. The concrete die dimensions are generally assigned to the next lower modular dimension (rounded down). The number of pistons can be read in the adjacent column ②.

The point of intersection with the SlipGrip characteristic ③ represents the necessary clamping force ④ and carrying capacity ⑤.

If necessary, the number of SlipGrip ledge clamps must be increased or, if possible, a larger version selected.

#### SlipGrip length

The length of the SlipGrip elements is usually based (table-flush dies) on the die dimension in slide direction). For this, this dimension is rounded down to the next modular dimension ①.

#### For clamping-free overtravel zone

To determine the number of clamping-free pistons (only carrying), the length of the overtravel zone is also rounded down to the next lower modular dimension ①.

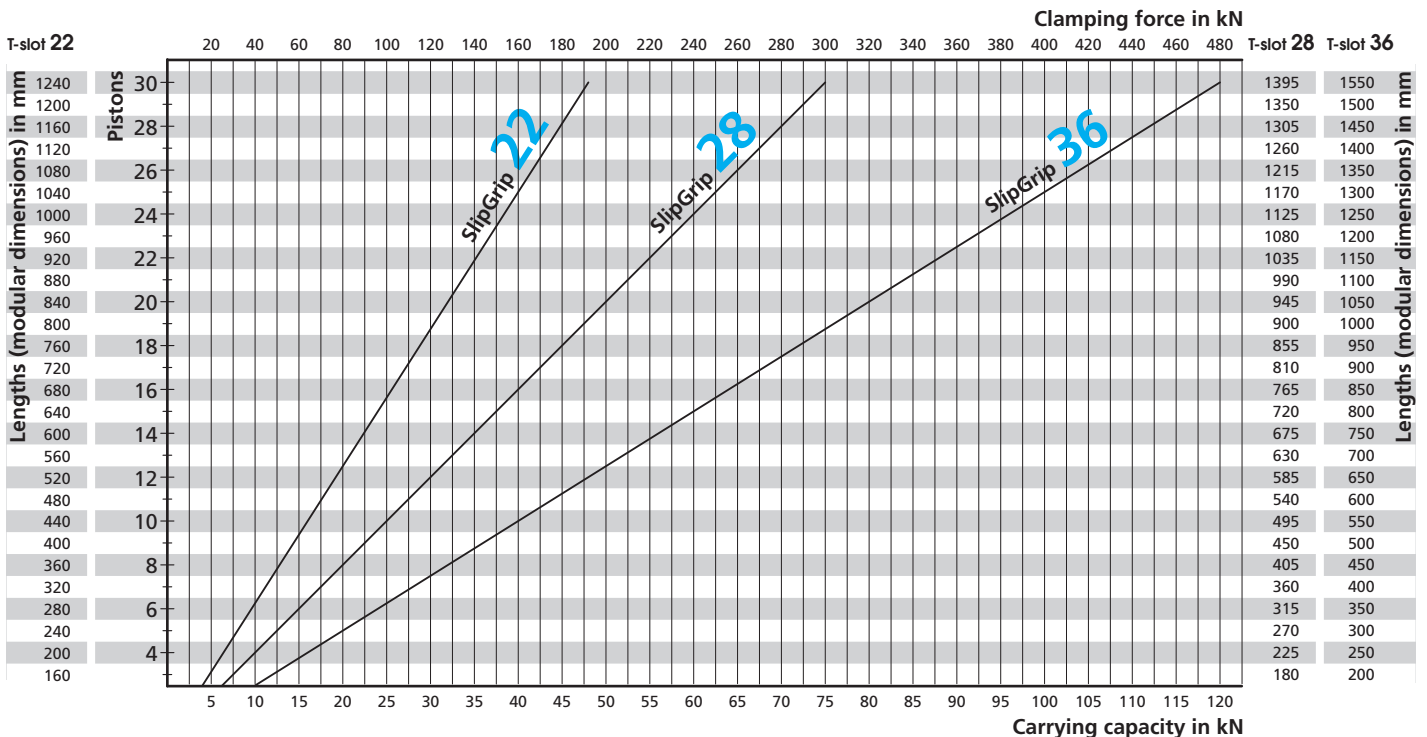

The guide to simple and exact

# → ORDER DESIGNATIONS

## FOR DILOS SLIPGRIP

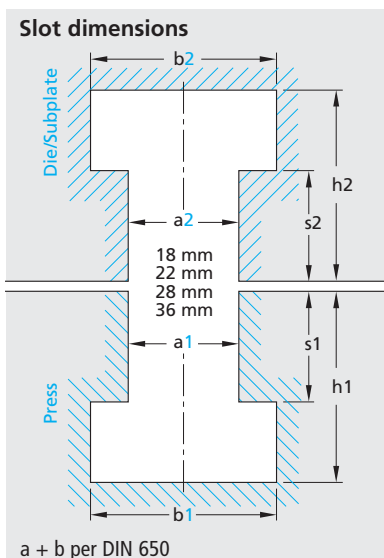
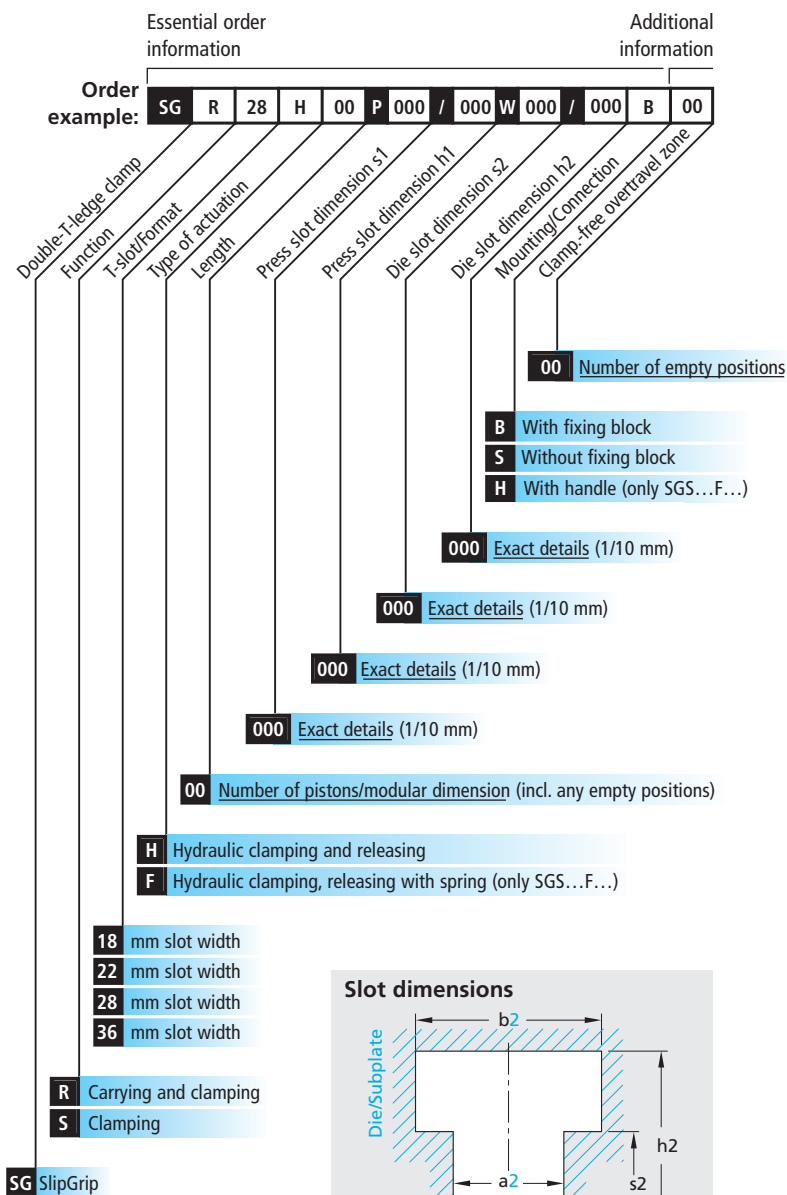

### Inquiry example

All actual slot dimensions (s1, s2, h1, h2) available must be specified in an inquiry.

# DILOS SLIPGRIP MOUNTING AND PRESSURE OIL SUPPLY

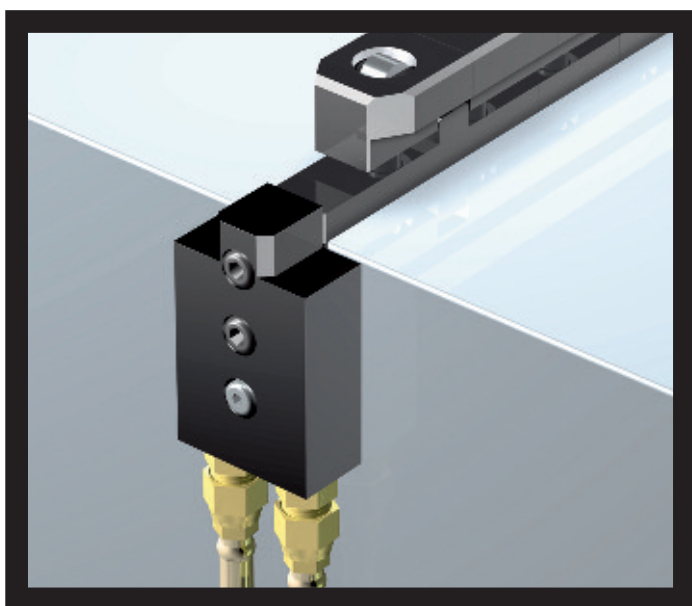

## Fixing block with integrated hydraulic connection

This universal DILOS fixing block SGF... is used to fasten the DILOS SlipGrip ledge clamps in a 'floating' connection by screwing them in the T-slot.

The fixing block can simultaneously be used as hydraulic elbow connection. Flexible supply hoses are needed for this.

## Clamping hydraulics

DILOS SlipGrip ledge clamps work with an operating pressure of 400 (250) bar.

We recommend our DILOS Hydraulic Unit (400 bar) for the hydraulic supply.

When used on hydraulic presses, it might also be possible to use the system hydraulics of the press for the hydraulic supply.



*DILOS Hydraulic Unit with frame construction. Pumps, control system and control valves are integrated in the unit*

# DILOS SLIPGRIP

## HIGH-QUALITY HYDRAULIC COMPONENTS FOR 400 BAR

### DILOS hydraulic valve sets

Seat valves (24 V DC) from leading manufacturers are used to control the DILOS double-T-ledge clamps.

The valves are mounted on a function block featuring a hydraulic test connection. This valve unit is usually mounted

directly on the DILOS Hydraulic Unit.

For the clamping elements in the ram, the valves can be positioned on a valve mounting plate in the ram area. This reduces the number of moving hose connections when using multiple clamping circuits.

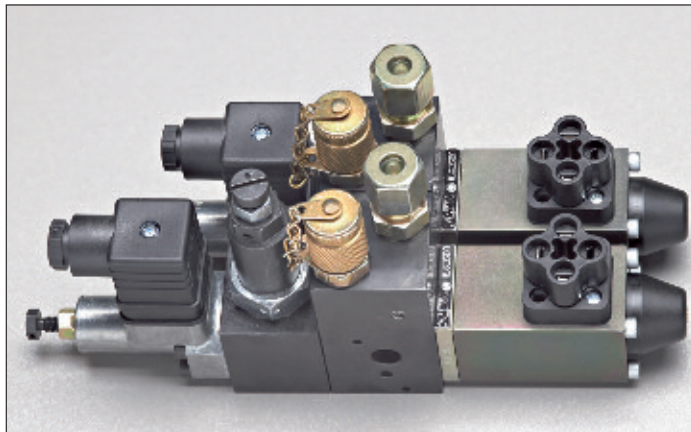

Hydraulic valve set for DILOS SlipGrip control

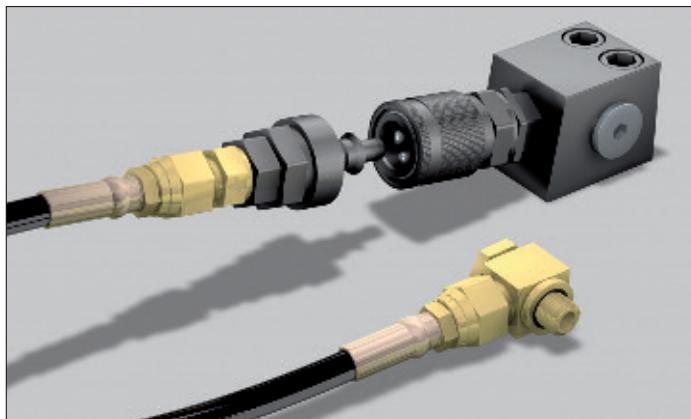

Hydraulic hoses with elbow connection G 1/4", e.g. for SGS...F..., combined with quick-action coupling and terminal block (pressure range 400 bar)

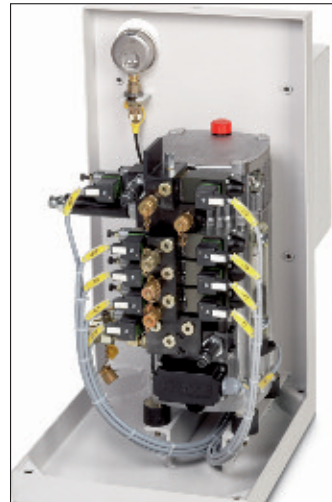

### DILOS Hydraulic Unit A

With intermittent operation

Electrical features: optional

Operating pressure: 400 bar

Flow rate: 1.5 litres/min

Tank volume: 4 litres

Useful volume: 2 litres

Driving power: 0.75 kW

Power supply:

400 V, 3 phases, 50 Hz

Speed: 1,360 rpm

Control voltage: 24 V DC

Hydraulic oil: HLPD 46

Optional: Elastomer dampers

### Ram application

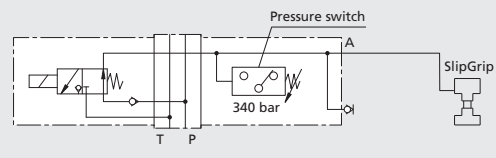

Valve set type E... for DILOS SlipGrip SGS...F...

### Table application

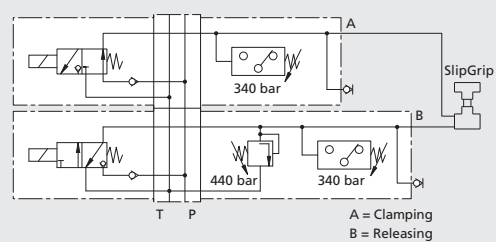

Valve set type S... for DILOS SlipGrip SGR...H..., SGS...H...

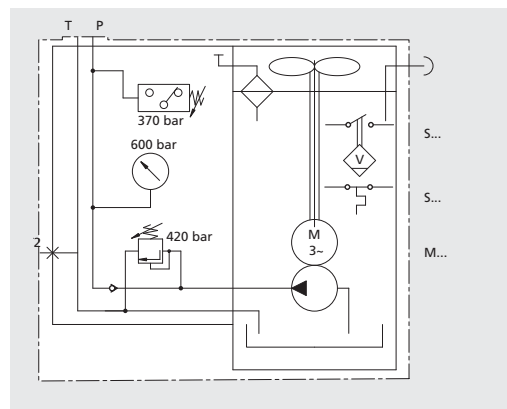

DILOS Hydraulic Unit A



**GÜTHLE**

**DILOS**

## DILOS SLIPGRIP SUB PLATES FOR QUICK AUTOMATED DIE CHANGES

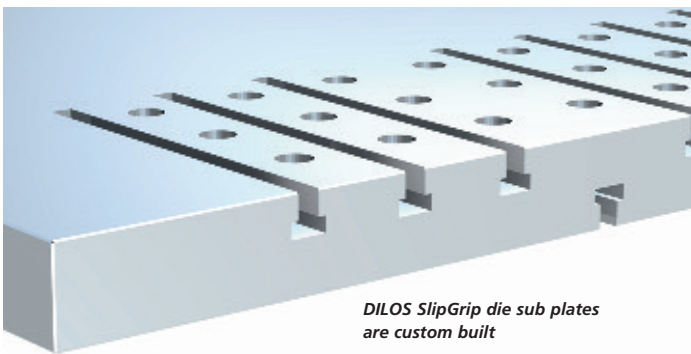

*DILOS SlipGrip die sub plates are custom built*

### Sub plate technology – the basis for rationalisation for frequent die changes

The use of SlipGrip subplates for frequent die changes makes it possible to devise standardised, highly rational change processes.

### Set-up and adjustment before the die change

Probably the biggest advantage of the sub plate technology is the considerable reduction in machine downtimes brought about by the fact that set-up is carried out completely outside the press.

### DILOS SlipGrip subplates are custom built

Dimensioning of the DILOS die subplates to customer-specific requirements makes it possible to design the 'table situation' to meet specific needs.

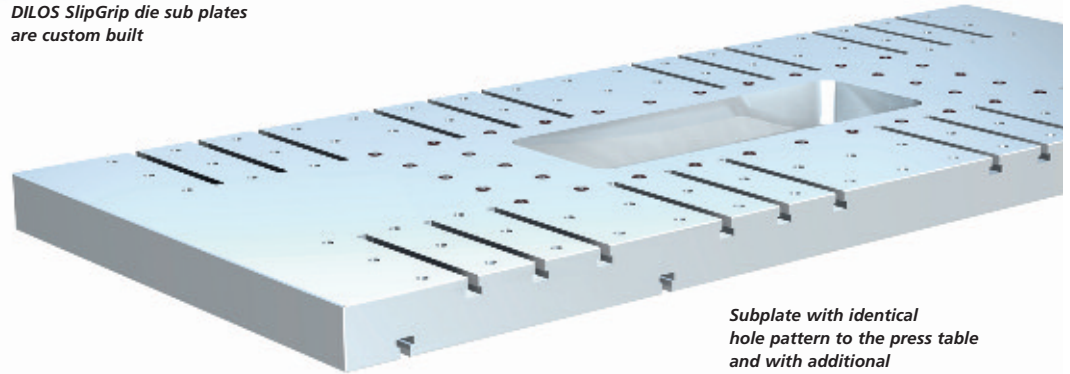

*Subplate with identical hole pattern to the press table and with additional spring-supported ROLLBLOC inserts*

### For rational die changing of differently sized dies

When using dies with differently sized base plates, DILOS subplates enable all possibilities for automated die changing.

### Use of adapted dies on a new press

DILOS SlipGrip subplates also make it possible to use existing dies on a new, larger press.

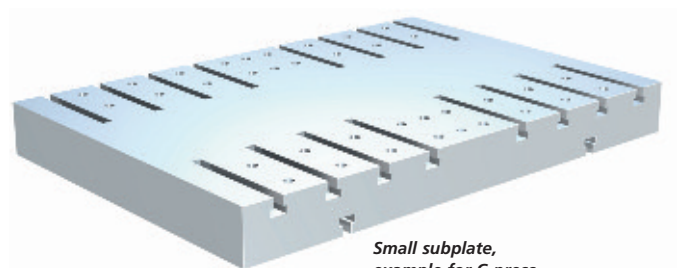

*Small subplate, example for C-press*



*Set-up tables for use of die subplates, shown here with the die transporter DILOS TRUCK*

### The advantages of DILOS SlipGrip subplates also come to the fore in relatively small presses

Frequent die changes on small presses are often not given as much attention as they should. Here quick die changes with DILOS SlipGrip offer immense potential to improve productivity.



**GÜTHLE**  
IDEA AND SYSTEMS

**DILOS**

# DILOS SLIPGRIP SUB PLATE TECHNOLOGY FOR MORE MACHINE RUNNING TIME

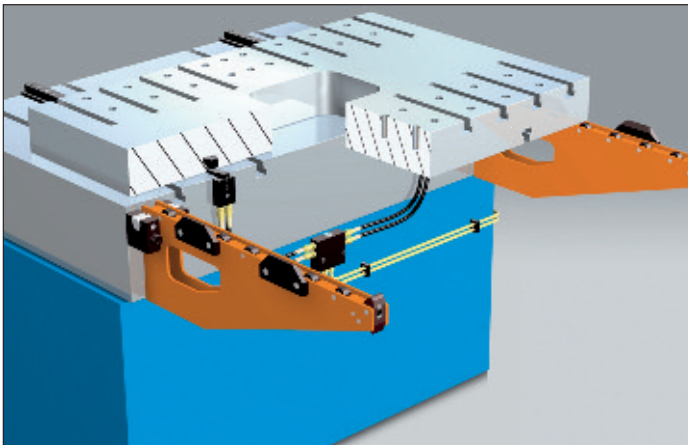

## SlipGrip sub plate technology, e.g. for crane transport

The figure above shows a typical example of an application for smaller presses. The die loading arms with lateral guides come from the ROLLBLOC catalogue programme from Güthle.

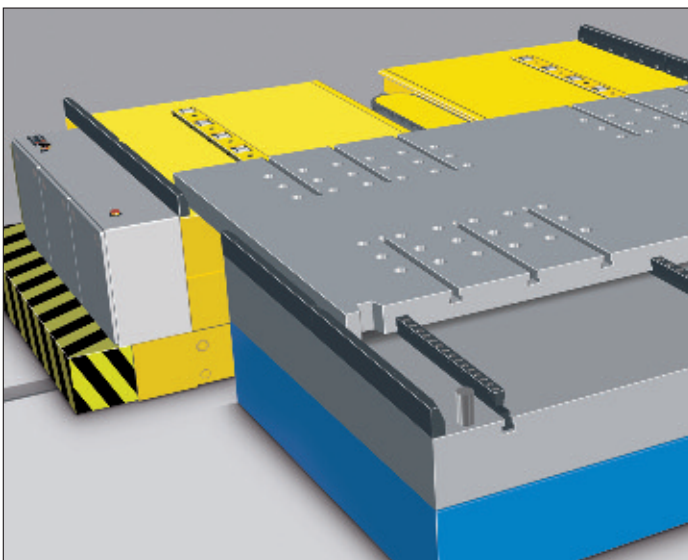

## Automated die changing with SlipGrip sub plate technology and die-changing cart DILOS SHUTTLE

The modular concept of the rail-mounted die-changing cart DILOS SHUTTLE enables adaptation to practically every situation.

With the tandem version the press is unloaded and loaded in the shortest time possible. The die change can be automated completely without any manual intervention.

## DILOS system technology

DILOS stands for DIE LOGISTIC SYSTEM.

This die logistics system includes all presses and in-plant die service stations into the rationalisation system for die handling, die maintenance and die storage in press and punching plants.

## The DILOS Product Range

### Die Handling Truck

(free-travelling)

DILOS TROLLEY

DILOS BUGGY

DILOS TRUCK

### Die Handling Truck

(on rails)

DILOS SHUTTLE

### Storage Technology

DILOS Universal Rack

DILOS Modular Rack

### Die Loading Arms

DILOS Special Die Loading Arms

DILOS Motor Die Loading Arms

### Clamping Technology

DILOS Swing Sink Clamp

DILOS Sub Plate Technology

DILOS SlipGrip

## Consulting

The rationalisation effect of this die clamping and changing technology offers significant practical advantages.

To optimise the function and expenditure, it is advisable to contact us in the initial stages of your design process. We can offer you our wealth of experience in the end-to-end automation of die changing processes.

We can provide you with professional advice – with no obligation on your part.

## GÜTHLE Service

Upon request, GÜTHLE will supply you with a complete solution – right down to the professional commissioning by our own plant fitters or by a service partner from your local area.

## Güthle Pressenspannen GmbH

Gottlieb-Haeefe-Strasse 9

73061 Ebersbach

GERMANY

Tel.: +49 7163 99090

Fax: +49 7163 990990

E-mail: [info@guthle.com](mailto:info@guthle.com)

[www.guthle.com](http://www.guthle.com)

## Please also consider our

### ROLLBLOC product programme

It comprises especially our well-known ROLLBLOC die lifters and hydraulic ROLLBLOC die clamps in various versions. The programme also contains various versions of die loading arms for safe and quick die transfer.